

SERIE AG 2000

SERIES AG 2000

Automazioni per cancelli ad anta scorrevole
Automations for sliding gates

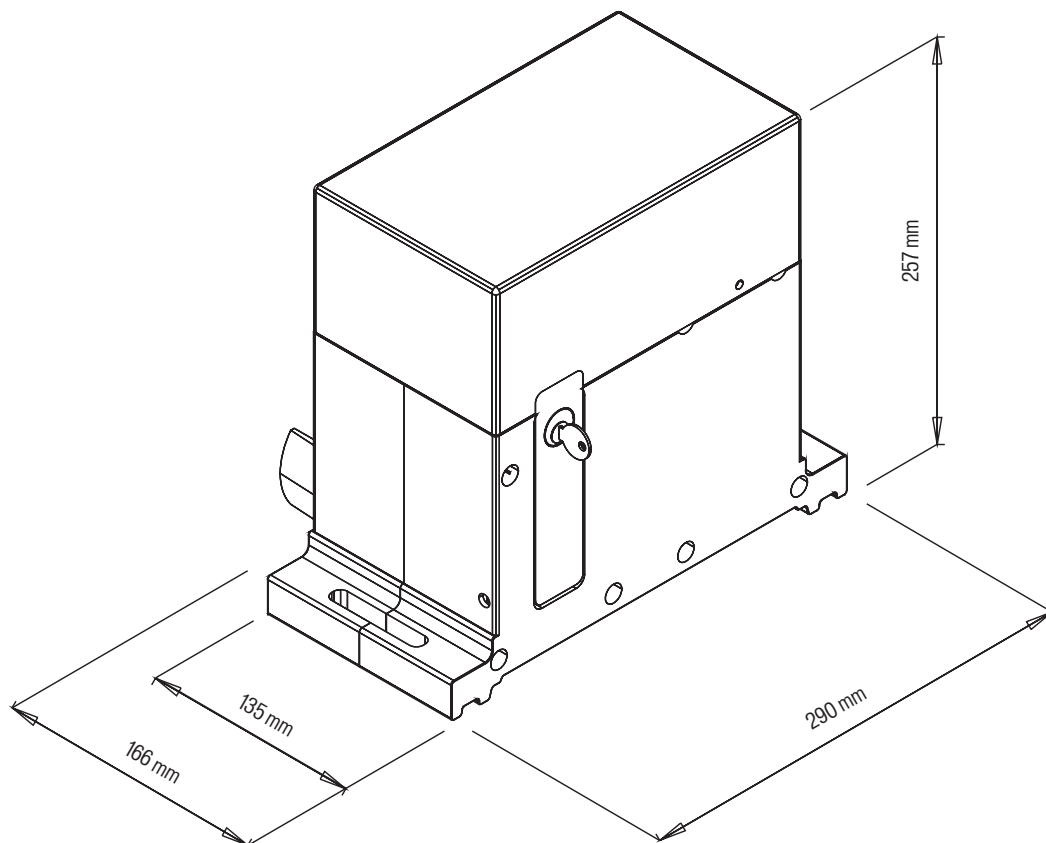

CARATTERISTICHE TECNICHE SPECIFICATIONS

	AG 2000 800 kg	AG 2000 1000 kg	AG 2000 1600 kg	AG 2000 1600 kg trifase
Alimentazione Motore - <i>Motor power supply</i>	230 Vac	230 Vac	230 Vac	380 Vac
Peso max. cancello - <i>Max. gate weight</i>	800 Kg	1000 Kg	1600 Kg	1600 Kg
Giri Motore - <i>Motor rpm</i>	1400 rpm	1400 rpm	1400 rpm	1400 rpm
Pignone - <i>Pinion</i>	M4-Z16	M4-Z16	M4-Z16	M4-Z16
Assorbimento medio - <i>Average consumption</i>	1,1 A	1,7	1,8 A	1,5 A
Potenza motore - <i>Motor rating</i>	270 W	330 W	360 W	500 W
Condensatore - <i>Condenser</i>	12.5 µF	16 µF	16 µF	-
Peso operatore - <i>Actuator weight</i>	13 Kg	13 Kg	13 Kg	13 Kg
Rumorosità - <i>Noise level</i>	< 30 dBA	< 30 dBA	< 30 dBA	< 30 dBA
Temperatura di esercizio - <i>Working temperature</i>	-20/+55° C	-20/+55° C	-20/+55° C	-20/+55° C
Intervento termico - <i>Thermal cut-out</i>	140° C	140° C	140° C	140° C
Fine corsa - <i>Limit switch</i>	Elett.	Elett.	Elett.	Elett.
Frequenza di utilizzo - <i>Frequency of use</i>	50%	50%	50%	80%
Velocità a vuoto - <i>Unladen weight</i>	10 m/min	10 m/min	10 m/min	10 m/min
Grado di protezione - <i>IP/rating</i>	IP44	IP44	IP44	IP44



VDS - VIA CIRCOLARE, SN - 65010 SANTA TERESA DI SPOLTRE (PESCARA) - ITALY
TEL. +39 085 4971946/+39 085 4972087 - FAX +39 085 4973849
WWW.VDSPRODUCTION.IT - VDS@VDSPRODUCTION.IT

VDS

AG2000 800 kg

